

## Machine **Direct Drive Rotary Axis Table**

Customer **Defence Application**

MTT will study your application and specifications and provide a formal quote, including a concept design plan, and projected engineering and manufacturing investment requirements.

We have extensive experience in designing or adapting machines with high accuracy specifications or harsh environments including nuclear and aerospace.



### Original Machine Condition

- Rotary axis did not have the required accuracy due to the thermal effect
- Thermal Analysis was carried out on the Rotary Table at the customer's site in accordance with ISO 230 part3
- The thermal growth of the table in the Z Axis was greater than 0.200mm, 0.074 in X axis and 0.042 in Y axis
- The OEMs recommendation was to use flood cooling to reduce the thermal expansion. This was an unacceptable solution for the required process, so MTT was commissioned to redesign the table



### Refurbishment Specification

MTT modified this machine in relation to specific operational requirements.

- Dismantle to table
- Measure all components and create a 3D model
- Redesign the housing including all features required to manage the thermal effect
- Redesign of the clamping system
- A smaller torque motor was installed, in line with process requirements
- Cooling channels were added to the bearings
- Installation of temperature monitoring devices at the bearing
- Redesign to include integration of thermal barriers which were manufactured from technical ceramics
- Once these changes had been completed, the thermal analysis was repeated under the same test conditions and the thermal growth of the table in the Z Axis is now less than 0.020mm

MTT can modify your CNC machine at your facility. We can also transport machines to MTT's modernisation facility to minimise disruption to your manufacturing environment.

By choosing one of our four key services you could extend the life of your machine

**Retrofit   Rebuild   Remanufacture   Design & Build**



Machine Tool Technologies Ltd, 1H Ribble Court, 1 Meadway  
Shuttleworth Mead Business Park, Padiham, Lancashire, BB12 7NG, UK

## Design & Build

3D Model of table

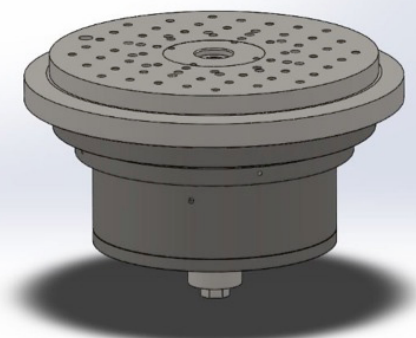

After Modification

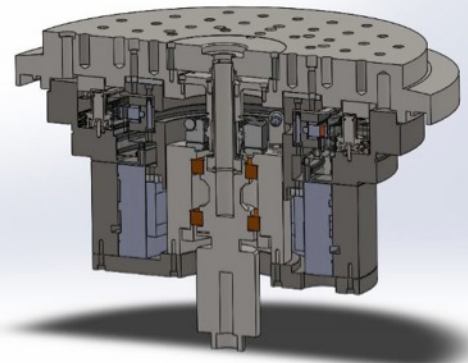

To talk with one of our engineers  
or book a machine assessment

Contact us now on  
**0845 676 9886**

or email  
**info@mtt.uk.com**